

Chaos

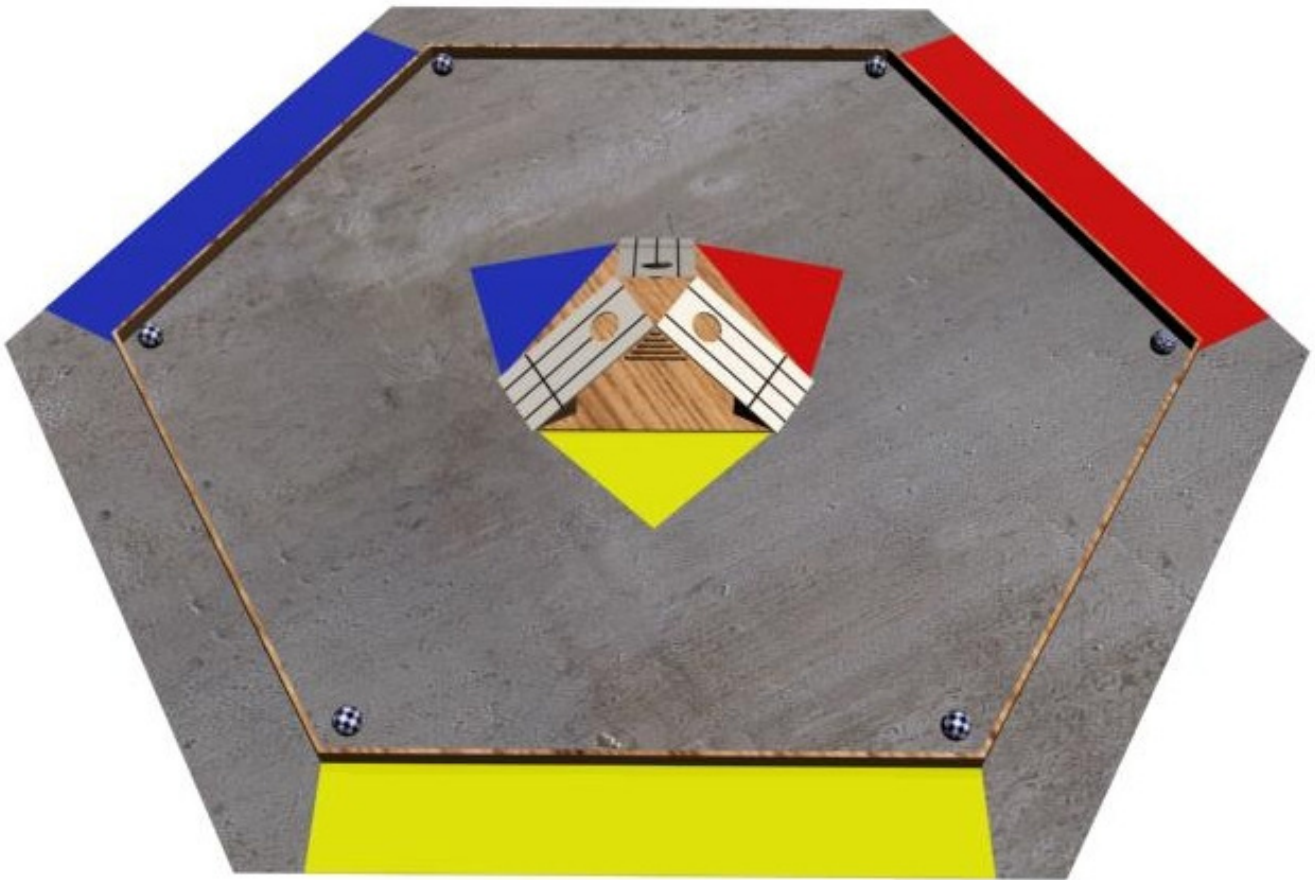

Date: April 18, 2007

Abbotsford

The 2007 BC Skills Canada Provincial Robotics Technical Committee:

Allan Byres, BC Chairperson and Pacific Region Representative

abyres@richmond.sd38.bc.ca

Randy Grey

greybay@shaw.ca

Andrew Kay

akay@istar.ca

Loren Boyle

Loren_Boyle@bcit.ca

Dave Daniels

cambria28@shaw.ca

Alex Lam

alex.lam@bchydro.bc.c

Table of Contents

Table of Contents	Page 2
Skills/Compétences 2007 Robotics Challenge Scope	Page 3
Mission Statement	Page 4
The Game – Basic Objectives	Pages 5 & 6
Game Standards	Pages 7
Game Play	Page 8
Game Scoring	Page 8
Round Robin Tournament Standing	Page 8
Round Robin Play	Page 8
Playoff Play	Page 8 & 9
National Court Layout	Page 9
Target Objects	Page 9
Robot Restrictions	Page 9
Overall Robot Size	Page 9 & 10
Overall Weight	Page 10
Allowed Parts List	Page 10
Power Sources / Management	Page 10 & 11
Non-Electrical (Battery) Energy Sources	Page 11
Radios	Page 12
Pit Area	Page 12
Further communications	Page 12
Overall Chaos Court Dimensions	Page 13
Center Pyramid Goal Structure Base Plate	Page 13
Goal Ramps / Ramp Supports	Page 14 & 15
Deflecting Pyramid	Page 15 & 16
Pre-inspection for Compliance with Safety and Design Rules Form	Page 17

Skills Canada 2007 Robotics Challenge Scope

Level: High School

Duration: Provincial - 6 hours

Purpose of the Challenge: To create an engineering project to encourage individuals with different skill sets to form co-operative teams to design, fabricate and operate a robot.

Tested Skills and Knowledge: Drafting, mechanics, electronics, metalwork, wood work & communications

Equipment and Materials:

Supplied by the Competitors: Robots, robot accessories, batteries, battery charger, extension cord, power bar, various tools required to modify and repair robots on site and safety equipment including mandatory eye protection.

Supplied by the Committee: Playing Field, timer, one 120V power outlet (minimum 100W), one worktable.

Judging Criteria: On the court performance of the end product (Robot) in the set task.

Team Size: 8 Students maximum (Provincial Only)

Number of Teams: 1 Team Per School unless space permits, Please contact the Chair to request an extra space.

Mission Statement

The primary intent of any Skills/Compétences Canada Robot Challenge is to have teams of students independently design and build robots capable of completing the competition tasks and to compete with robots which are student-fabricated. Teams must avoid the purchase, re-use or adaptation of complete systems that were commercially fabricated to address a task set very similar to the Skills Canada Challenge. Teams MAY use the design of commercial mechanisms or systems, which can complete some tasks of the Skills Canada Challenge, but they must fabricate the mechanisms themselves. It is expected and acceptable that teams will use some newly purchased and recycled parts or components (motors, gears, etc.) to fabricate mechanisms, which will complete the Skills Canada tasks.

Please see list of the acceptable parts in the robot construction constraints section.

Provincial technical committee members will make checks for adherence to this statement, at their provincial competition, before any team advances to national level competition.

Teams that do not have a provincial competition should submit their design questions to the regional representative for their area or to the National Chair.

The Game: Basic Objectives

1. Robots will navigate over a smooth hard surface. This surface will be either the facility floor (concrete) or plywood.
2. Each Robot will be assigned a starting position aligned with the Center Goal Structure.
3. Each Team will be assigned a Team Space opposite their Robot's starting position.

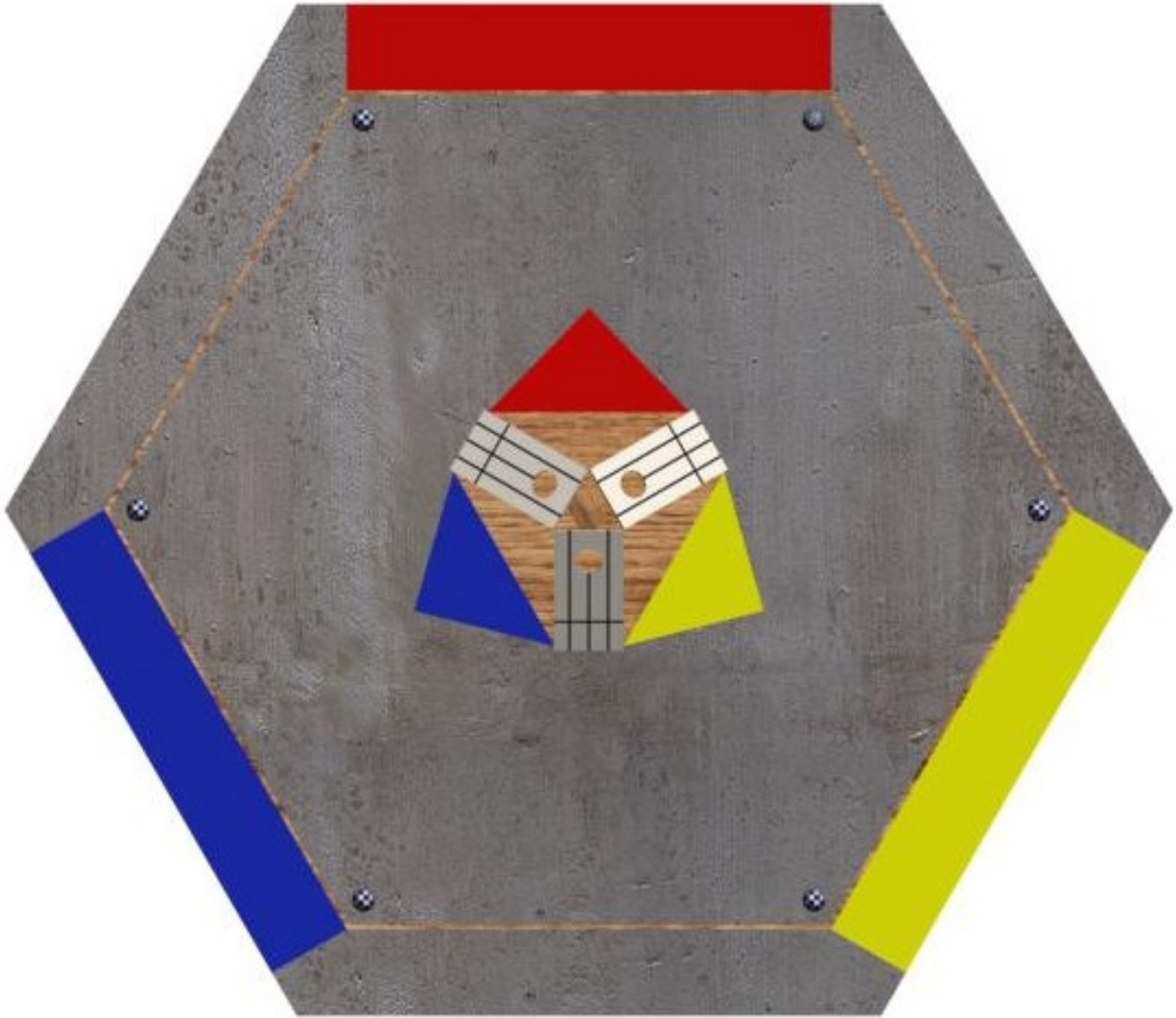

4. There will be a Fixed Position Center Pyramid Goal Structure.

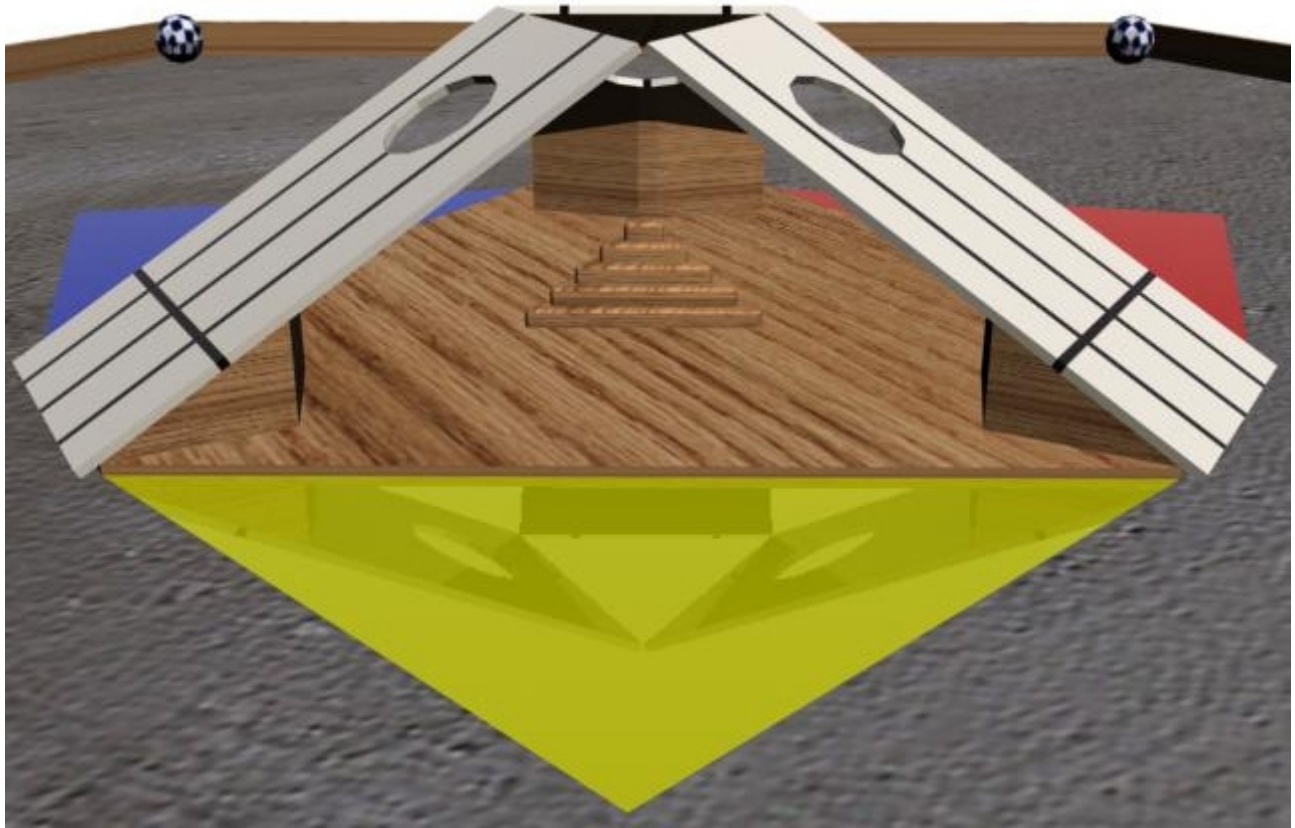

5. There will be THREE Ramps in the Center Pyramid Goal Structure. Each of these Ramps will have a $\frac{3}{4}$ inch wide Black Electrical Tape Horizontal Crease Line located 12 inches up from the base of the ramp. They will also have a Three Vertical $\frac{3}{4}$ inch wide Black Electrical Tape Lines running parallel up the ramp to the Circular Goal Opening and passing by to the top of the Goal Ramp (see diagram).
6. There will be a pyramid at the center of the Goal Structure Base to deflect Target Objects out and back onto the court floor.
7. There will be barriers under the ramps to prevent the Target Objects from becoming pinched under the Goal Ramps.
8. There will be SIX Target Objects (see www.cambierobotics for ball details) on the court at the start of each game.
9. ONE Target Object will be placed on the open court floor at each corner of the Hexagon shaped court.
10. Robots may be IN POSSESSION of a MAXIMUM of TWO Target Object's at a time.
11. Target Objects MUST remain in contact with the Court Floor while they are in the possession of robots. Possession implies controlled rolling of the Target Object by a Robot.
12. Simple Bumping of a Target Object by a Robot will NOT be considered as being in possession of that Target object.

Court Details are available in the Appendix Section located at the end of the scope.

Game Standards

1. During the competition, students must maintain safety at industry standards. Team members without required safety equipment will not be permitted into the competition area.
2. During game play, referees will have ultimate authority over game rulings, and will have full authority over team conduct in the court area.
3. Damaging the **court** and or the **target objects** is illegal. If a robot's design causes damage to the court or the target objects then it will not be allowed to compete until it can operate without causing damage. Games missed due to this will be forfeited.
4. Deliberate strategies aimed at the destruction, collision, damage, overturning, entanglement or active blocking of competitor robots are not in the spirit of the game and are strictly forbidden. Forfeiture of, and removal from the match will result with the first occurrence. Expulsion from the games will occur after the second. Ramming and pushing are not allowed.
5. Games will start on time. Teams are responsible to know when their games are scheduled. **Teams arriving late will forfeit the game.** They cannot use the remainder of the time in the game.
6. If teams must withdraw from a scheduled game due to mechanical problems then they are asked to inform the Referee as promptly as possible of their decision to 'Forfeit the Game'.
7. Competitors cannot enter onto the court surface or make adjustments to their robot during a game. NOTE: If a robot is mal-functioning and represents a hazard to participants, other robots or itself in the opinion of the Referee, then, the referee may stop the clock, and may authorize the removal of that robot from the court during a game. Disabled robots or parts of robots not generating any safety concerns may be left on the court until the game time expires.

Game Play

NOTE: Deliberate Ramming of an Opponent Robot will not be allowed. HOWEVER, ALL Robots must be built in a robust and durable manner given that it is expected Robots may accidentally collide. Robots will likely be struck by 'Missed Shots' and protection of sensitive components should be a design consideration.

1. Teams will be allowed Two Competitors in the court side area.
2. At the start of a game, Robots must be in their assigned starting positions.
3. All Target Objects will be a shared resource during game play.
4. Competitors must remain outside the court boundaries.
5. Drivers must remain in their assigned Team Area throughout the game.
6. Spotters may move freely within the 3 Shared Spotter's Areas.
7. Spotters may NOT enter an Opponent Team's Area.
8. Robots must not leave the competition court at any time during a game.
9. It will be a referee's ruling that decides if an 'End of the Game Shot' took place before or after the game-ending buzzer sounded.
- 10 Target Objects landing outside the court boundaries WILL BE RETURNED to the court.
13. Robots may NOT retrieve any Target Objects that come to rest on the Center Pyramid Goal Structure.
14. Robots may NOT enter INTO or ONTO the Center Pyramid Goal Structure.
15. Robots may not drive onto the Goal Ramps.
16. No part of a Robot may pass the Goal Crease Line (12 inches up from each Goal Ramp Base) at any time.

Game Scoring

- a) Each Target Object delivered into the 10 Inch Diameter Holes in each of the Center Pyramid Goal Structure Ramps will be assigned a value of TWO Points.
- b) Each Target Object delivered into the Triangular Opening at the top of the Center Pyramid Goal Structure will be assigned a value of ONE Point.

Round Robin Tournament Standing

Round Robin Tournament Standing points will be awarded in the following pattern based on individual game results:

3 Tournament Standing Points will be awarded to the First Place Team in each Game

2 Tournament Standing Points will be awarded to the Second Place Team in each Game

1 Tournament Standing Point will be awarded to the Third Place Team in each Game

Note: A Team must score a minimum of ONE Point to be awarded Tournament Standing Points.

Note: IF a tie occurs for 1st then both Teams will be awarded 3 Tournament Points and there will be No Second Place Team in that game.

Note: IF a tie occurs for 2nd then both Teams will be awarded 2 Tournament Points and there will be No Third Place Team in that game.

- a) A Game Score of zero (0) will be assigned for robots that do not show up for (Default) a game.
- b) Total Points scored in all games played will be used to break Round Robin Standing Ties.

Round Robin Play

1. Up to THREE Robots will play on the court in round robin games.
2. Round robin games will last 4 minutes.
3. The amount of time between games will be determined by the number of participants. This information will be provided to teams at the start of the round robin.
4. Between round robin games, battery changes and repairs to robots may be completed.
5. All robots should expect to play at least 10 games in the round robin

Playoff Play

1. The top 6 teams will advance to the Playoffs.
2. Two Robots will play on the court in Playoff games
3. Finals games will last 4-minutes.
4. The time between Periods of Playoff Games will be 8 minutes.
5. Teams will move their Robot to the pit area for the 8 minutes between Playoff Game Periods.
6. There will be no restriction on the courtside work Teams may do to their Robot during the 8 minutes between the Periods in Playoff Games.
7. Teams not prepared to start the next Period at the end of the 8 minutes between Playoff Periods Repair Time will default that Playoff Period, but they will remain in the game.
 - a) If the defaulting team is behind in the score the game is over.
 - b) If the defaulting team is ahead in the score then they will win if they remain ahead at the end of the period in which they did not participate.

c) If the defaulting team is ahead in the score and a Tie Score develops at the end of the period in which they did not participate then they will be eligible to join the Tie Breaking Period if they have completed their repairs.

8. Playoff Games cannot end in a Tie. If a Tie Score exists after the 2 Period Game then additional 4 minute Periods will be played (as many as needed) until one of these extra Periods ends with one Team ahead. Note: Rules 5, 6 and 7 remain in effect and will be applied to the time between the extra periods of Playoff Games.

9. Playoff games will be held based on the Final Round Robin Tournament Standings.

10. The Playoff Game Pattern will vary depending on the number of Robot Team's participating. The Specific Playoff Game Pattern will be announced to the Teams at the competition site.

Provincial / National Court Layout

Please note: Although great pains will be made to keep the court in compliance with the drawings, some inaccuracies in construction may occur. Please make your robot designs allow for a possible 1/2" tolerance.

Detailed Court Information has been included in the Appendix Section of this scope document.

Target Objects

The Target Objects are Number 5 Soccer Ball / Approximate Diameter 8 inches.
(see details at www.cambierobotics.com)

Robot Restrictions

All Robots must PASS a pre-competition inspection for compliance with the safety and design rules before they will be allowed to participate in Tournament Games. Note: Robots must remain in compliance with these rules throughout the competition. If Teams fall out of compliance with these rules then they will not be permitted to compete and will forfeit all of their scheduled games until they have corrected the problem.

ALL Robots MUST have a Robot to Robot-Defensive Contact Area on the majority of the Robot's Perimeter. This Defensive Contact Area MUST be a minimum of 2 inches wide and centered 4 inches above the Court Floor.

Overall Robot Size

Robots must not exceed an overall size of 8 Cubic Feet (13,824 cubic inches) at the start of each game. Robots may expand to a larger size once a game has started.

Overall Robot Size will be calculated by using the maximum single dimension in each category (Length / Width / Height) of the Robot not average dimensions.

This overall size maximum will allow a Robot to be any of the following example sizes, or indeed some other variation that does not exceed 13,824 cubic inches:

- (a) an overall dimension of **24 by 24 by 24-inches**, (13,824 cubic inches), or
- (b) an overall dimension of **42 by 18 by 18-inches**, (13,608 cubic inches), or
- (c) an overall dimension of **36 by 21 by 18-inches**, (13,608 cubic inches), or
- (d) an overall dimension of **48 by 24 by 12-inches**, (13,824 cubic inches).

NOTE: The Top of your Radio Antenna may be a Maximum of 48 inches above the court floor. The Radio Antenna is not considered when defining the Overall Robot Size.

Overall Robot Weight

No weight restriction is imposed on the robots.

Robots should be built with robustness in mind. Accidental bumps and scrapes will happen. Teams must consider protection of sensitive components and durability of exposed ones when designing all elements of their robots.

Allowed Parts List

A quick note about manufactured parts: Although it is impossible to create a comprehensive list of all acceptable parts, a list has been made to provide guidance for teams. Acceptable components: electronic speed controllers, motors, gears, sprockets, chains, belts, pulleys, tires, rims, bearings, compressed air tanks, gauges, tubing connectors, RC transmitters / receivers, servo motors, batteries, harvested gearboxes from mechanical devices...., PLC unit and interface.

Examples

Wheel assembly: tire, tube, hub & bearing.

Power plants, this could involve complete core systems. The intention is to enable power to be delivered to student created mechanisms.

1. A Power Drill where the complete Motor / Gear Box / Clutch/ Chuck is used.
2. An Automobile Power Head Rest Motor / Flexible Drive Shaft / Linear Gear Assembly are used.
3. A Photocopier Chain Drive involving the Motor / Drive Shaft / Drive Chain Sprocket is used.
4. A Photocopier Gear Box to be used to manage a non-photo-copier motor.
5. An Electric Scooter or Wheel Chair.

It is a team's responsibility to ensure robot compliance to standard. Members of the provincial and national technical committees will avail themselves as a confidential "sounding board" for team's design/parts choice.

Power Sources / Management

1. The total voltage in any individual circuit **cannot** exceed **24 Volts**.
2. The **Maximum continuous** power rating allowed in any circuit is **240 W**. Which will be limited by voltage and fuse selection. Example: $12\text{Volts} * 20 \text{ Amps} = 240 \text{ Watts}$
3. Teams are reminded that it is the purpose of a fuse to protect the students themselves and the equipment in their circuits. It is recommended that teams develop circuit diagrams, and calculate the appropriate values for all circuits on their robot.
4. Each current branch path from the battery must include either an **In-line Fuse, Circuit Breaker** or be connected to a dedicated fuse in a rack.
5. Teams must use a wire gauge, which is appropriate to the current values in each circuit.
6. Batteries must be complete sealed commercial battery packs.
7. All **wires** and **batteries** are to be mounted **securely** to the robot taking into consideration that they must be protected from damage due to abrasion when the various robot elements move.
8. Teams are responsible for charging their own batteries and must have a complete set of batteries. It is recommended that a spare set be available.
9. Teams may apply voltages to a motor up to 150% of the motor's marked rating. Note: Teams attempting this must thoroughly test their systems to ensure the motors do not "smoke" under all possible conditions.
10. Robots must be able to be turned off with a single motion. Radio receivers may be in an independent circuit.
11. Teams may use new or re-cycled motors. See list of allowable parts.
12. There is no restriction on the number of motors used on a single robot.
13. No explosive materials of any kind may be used (ether, gunpowder, acetylene etc.).

Non-Electrical (Battery) Energy Sources

1. Pressure based energy sources (air or other) may be pre-charged to a Maximum of 90 PSI pressure in their reservoirs (cylinders) at the start of each game.
2. Competitor-made or modified Air pressure systems are permitted as long as they do not exceed a maximum pressure of 30 PSI and they include a pressure relief valve set to trigger at 30 PSI.
3. All pressurized tanks on robots must have a pressure gauge to indicate the stored pressure and a form of automatic overpressure safety relief.
4. The pressure tanks and related gauges / controls must be shielded from damage due to collisions or flying Target Objects.
5. The stored pressure in the tank must not exceed a maximum of 90 PSI at any time.
6. Tension-based energy sources (elastics, springs or other) may be in either a relaxed at rest state or in a tense / compressed state at the start of each game.
7. Laser devices are prohibited.

Radios

1. All teams must use *ground frequencies (75 MHz)* for their RC transmitters or Park Flyer Radio Control units (ones with a limited performance range, 500 feet) which use 2.4GHz Spektrum DSM technology such as those described at http://www.modelflight.com.au/rc_model_radio_control/spektrum_dx6.htm. Note: IF any signal interference issues arise with WAN's or Phones when using the 2.4 GHz units then it is a Team Responsibility to resolve not the Robotics organizing committee.
2. Only six channels of one RC radio can be **used at a time**.
3. No radio telemetry from the robot is allowed.
4. New prototype RC controllers developed by Skills Canada British Columbia TC will be permitted.
5. All teams must report their radio information to the National Technical Committee in advance of the competition so that potential signal conflicts can be identified and resolved prior to the competition. It is a team responsibility to ensure that their radio does not interfere with an opponent's radio.

Pit Area

1. Only 'Registered Robot Competitors are permitted in the Pit Area.
2. Designated Teacher / Industry Team Advisors are permitted in the Pit Area ONLY to inspect the Work Table Setup of their team prior to the start of the Tournament.
3. Designated Teacher / Industry Team Advisors are NOT allowed in the Pit Area during Tournament and Playoff Play.
4. Teachers and industry advisors will have purely advisory role in the pits. They are not permitted to handle tools or robot parts. Students must affect all repairs and modifications on their robot.
5. Teams will be provided with *Pit Area Workspace* on a standard project table. Depending on the number of teams and availability of space, teams may have to **share** a 60 by 30 inch table.
6. Each Pit Area Table will have access to one electrical outlet. Teams are requested to bring a 25 foot multi-outlet extension cord / power bar as part of their equipment.
7. It is required that teams fabricate a **Table Top Stand** for holding their Robot in the Pit Area. This stand should hold the Robot securely and be capable of preventing the Robot from driving on or off of the table in the case of either deliberate motor testing during repairs or due to random, unexpected motor activity.

Further communications

All participating teams are expected to check the 2007 Skills Canada Robotics Competition Website at <http://www.cambierobotics.com>

for updated information beyond this paper. Questions for clarification of the rules can be made to any of the Provincial Technical Committee (see cover page for e-mail contact addresses).

Responses to these questions will be posted on the Skills Canada Robotics Competition Website.

Teams participating are expected to periodically check this site for updates.

Appendix

This section provides specific details regarding the Chaos Court.

The Overall Chaos Court Dimensions are:

Note: This court may be adjusted to fit on a 24 foot square if the facility floor is deemed unsuitable. This will not affect the centre pyramid in any way.

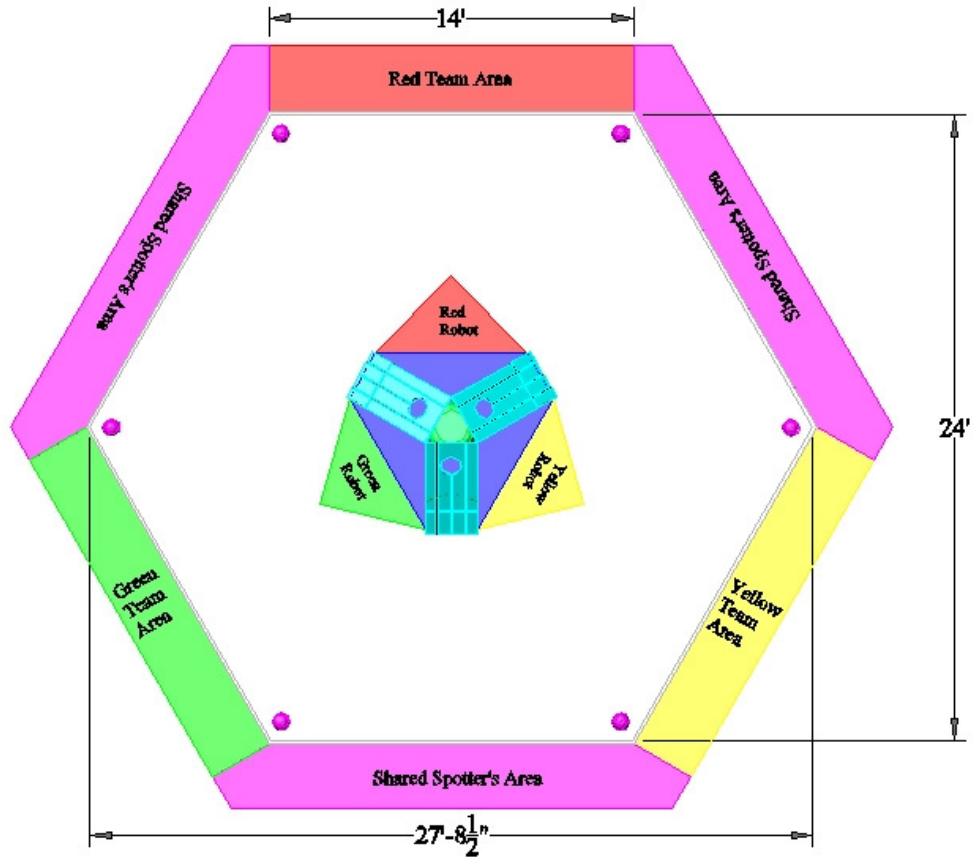

The Center Pyramid Goal Structure is built on a 3/4 inch thick Plywood Base Plate.

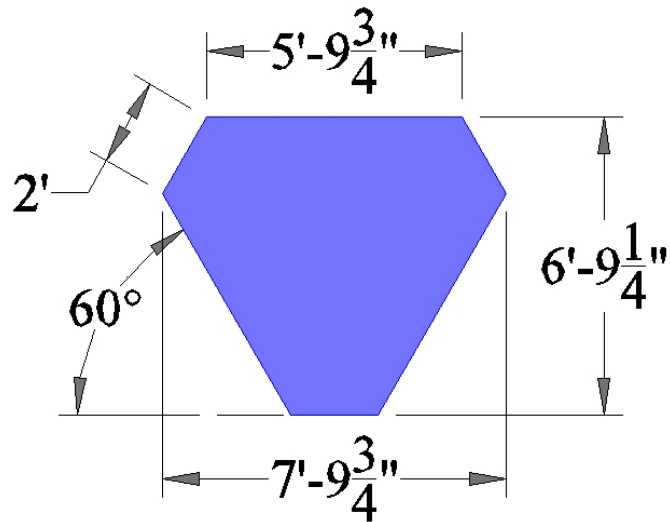

The Goal Ramps are made from $\frac{5}{8}$ inch thick White Melamine and they have a pattern of lines created using $\frac{3}{4}$ inch wide Black Electrical Tape.

There is a 10 inch diameter hole in the face of each Goal Ramp.

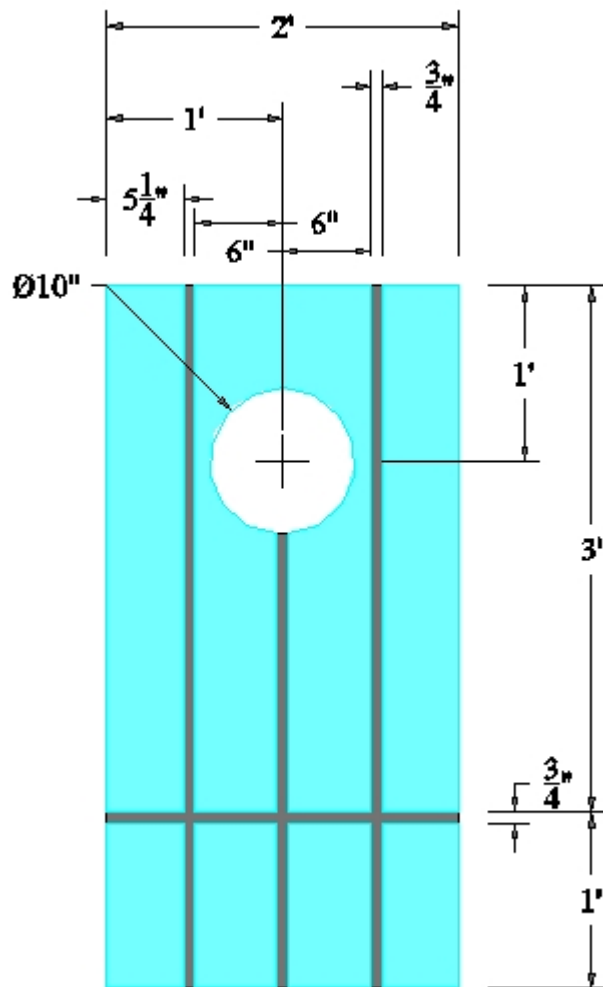

The Goal Ramps are positioned at a 30 Degree Angle.

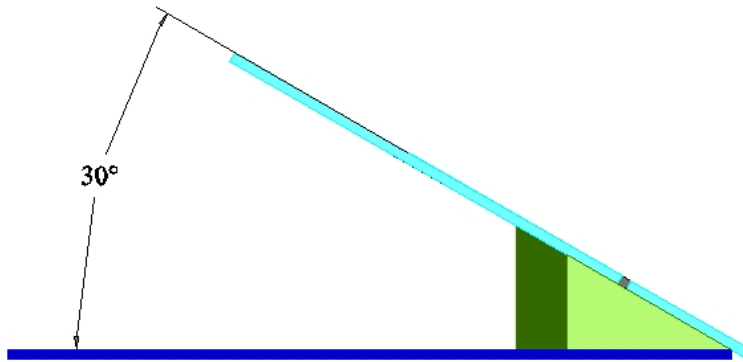

Each Goal Ramp is supported by a wedge shaped component.

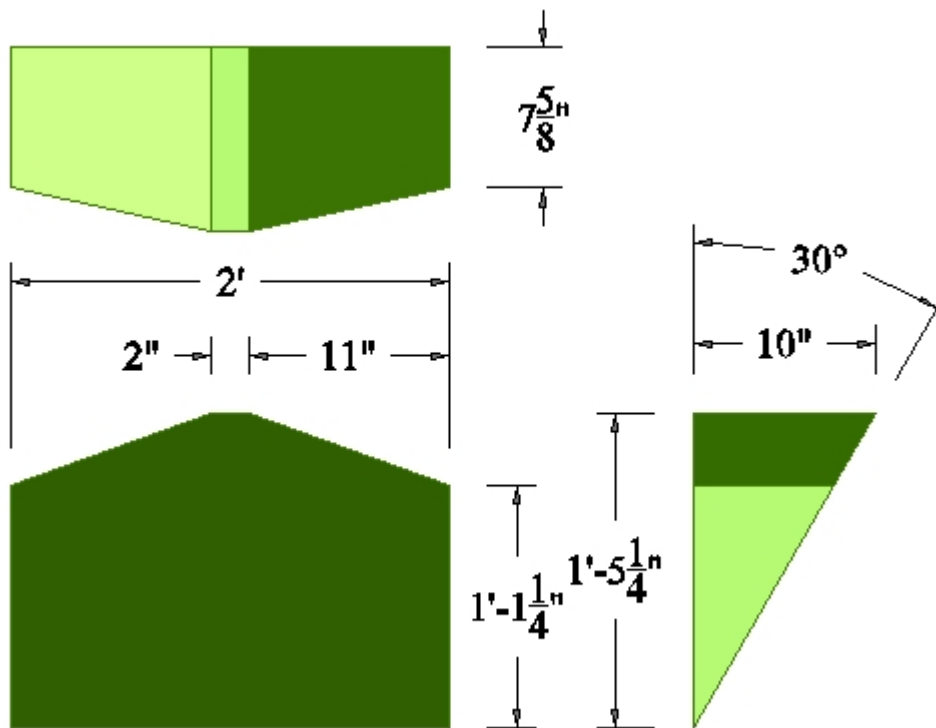

There will be a structure positioned at the Center of the Goal Structure Base Plate. This structure is intended to deflect Target Objects (Soccer Balls) back onto the open court surface. This structure is defined in the following set of diagrams.

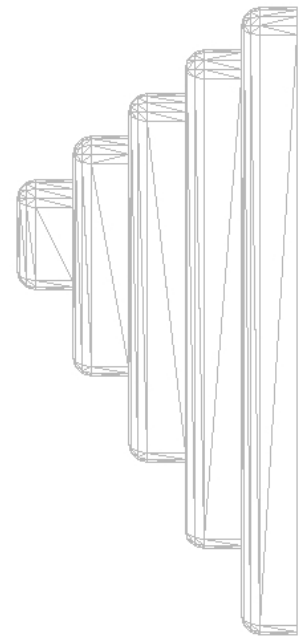
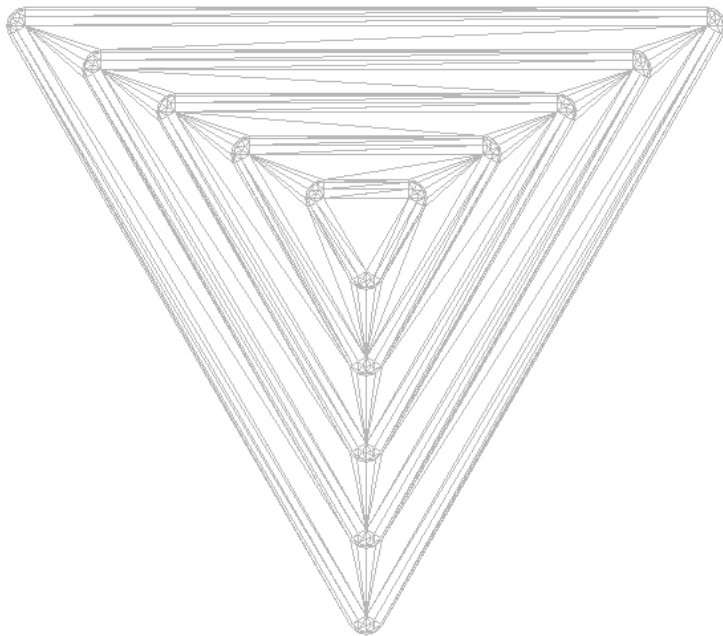
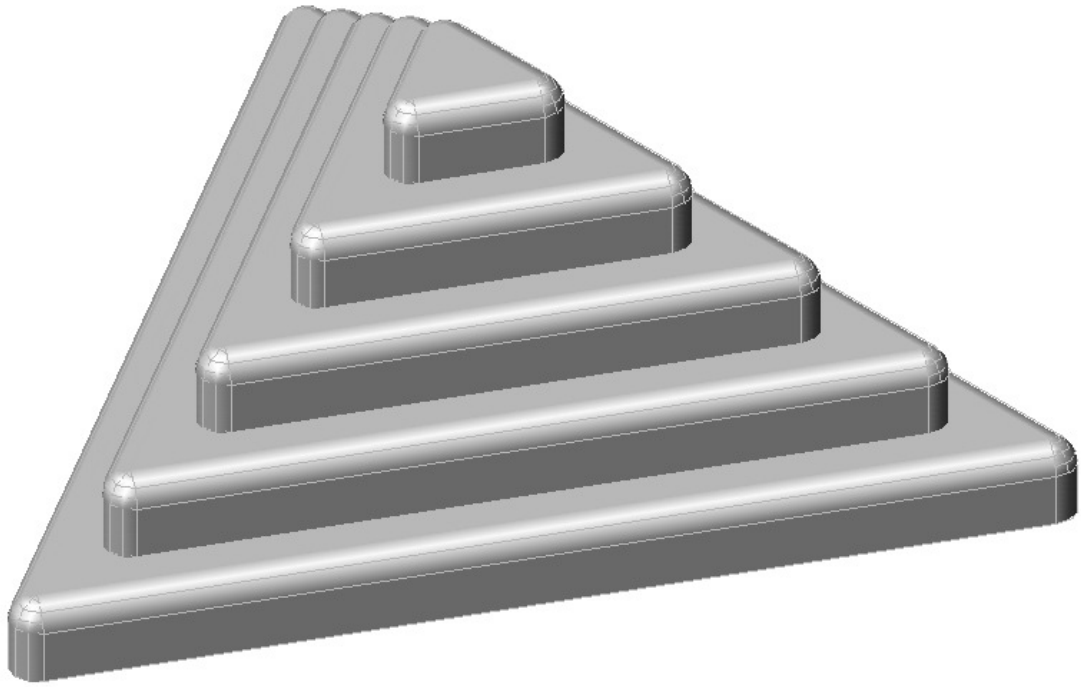

Center Deflection Pyramid without 0.5 inch Fillets

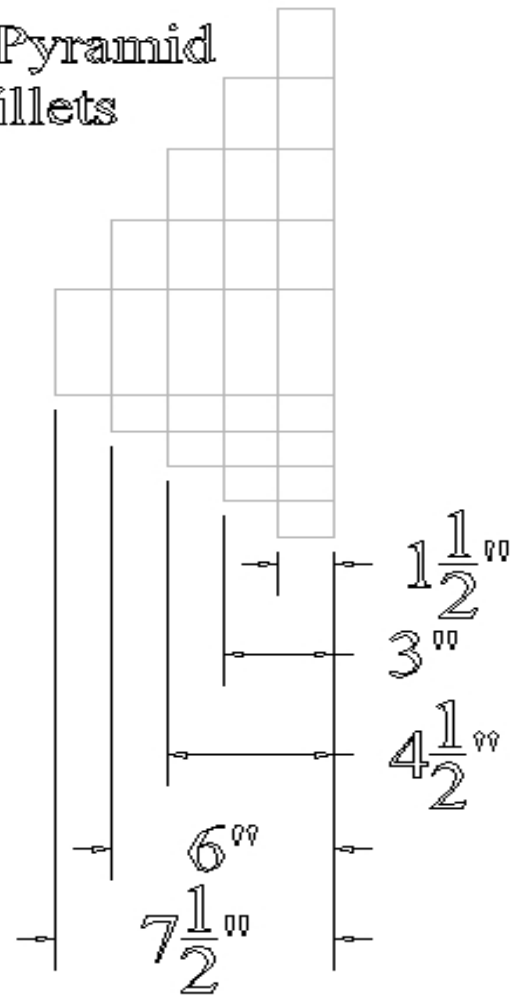
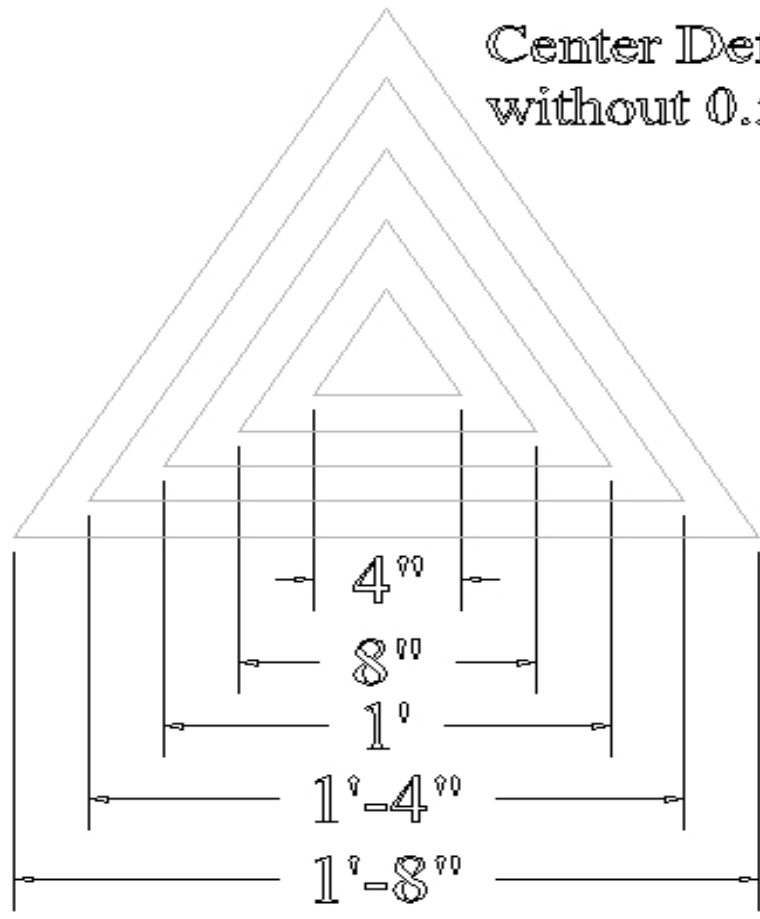



2007 Robotics Challenge

Pre-inspection for Compliance with Safety and Design Rules

- Overall volume $\leq 8 \text{ ft}^3$ (Antenna not counted) (or $13,824 \text{ in}^3$)
- Antenna $< 4 \text{ ft}$ from court floor
- No explosives/combustibles
- No lasers
- All batteries are sealed commercial batteries in good physical condition
- Batteries wired in series should be the same amp hour rating (ex. both 1500 mAh) and batteries in parallel are of same voltage (ex. both 12 volts).
- Batteries securely mounted
- Total voltage in any individual circuit does not exceed 24V
- No circuit exceeds 240W (Voltage x Fuse Current Rating)
- All circuits have a fuse or breaker (breakers must have **DC rating**)
- Appropriately gauged wiring for each circuit
- Wires and connections are in good physical condition
- Wires and connections are not exposed to physical abrasion
- Motors not over-voltaged by more than 50% (a 12V motor can be run at 18V)
- Wiring Diagram provided.
- Competitor-made or modified Air pressure systems do not exceed a maximum pressure of 30 psi and includes a pressure relief valve set to trigger at 30 psi
- Pressure tanks (cylinders) commercially manufactured if pressure in system exceeds 30 psi
- Pressure indicator
- Pressure in tanks does not exceed 90 psi (6.2 bar)
- Over-pressure safety valve
- Pressure tanks and related gauges and controls are shielded from damage due to collisions
- Robot is able to be turned off with a single motion. Radio receivers may be in an independent circuit.
- Only 6 channels of a single radio control unit are used for communications
- Demonstrate robot functionality with rated fuses

Additional concerns:

--	--	--

Robot Evaluator Signature

Team Representative Signature